

1. Make sure to correctly delimit, mark and clean the property boundaries and fence line so all the materials can be moved properly. Also, don't forget to mark out starting points or corners carefully so a post H can be installed there.

2. From the starting point or corner, mark every 98" Those will be the centers of the post "H" locations.

3. Using a post hole digger or any specialized tool, dig a 1 ft diameter hole, and 3 or 4 ft deep; dig footing to depth required.

4. In case of very hard or rocky soil the required depth may decrease from 15% to 30%; the remaining part of the post can be cut by 9-12" concrete saw, angle grinder, etc. If soil is very soft or doesn't have any strength the hole's depth should be at least 3 1/2 - 4 1/2 ft. An extension must be added at the bottom of the post (with a 1/4" corrugated steel rod), this will allow the post correct fastening to the ground which will make the fence resistant to strong winds. For more information on loose soil please contact us.

Note: The concrete panel at the bottom must rest on the concrete cast that was pour in the columns. If placed only on the ground, after years it can lose symmetry.

5. Mark inside the slot of the Post "H" 3 or 4 ft depending on the required depth.

6. Lower and position the post into the hole using a level; the mark of the post should be just above the height of the hole.

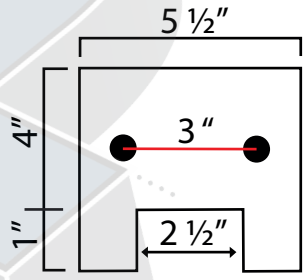

Top Rail

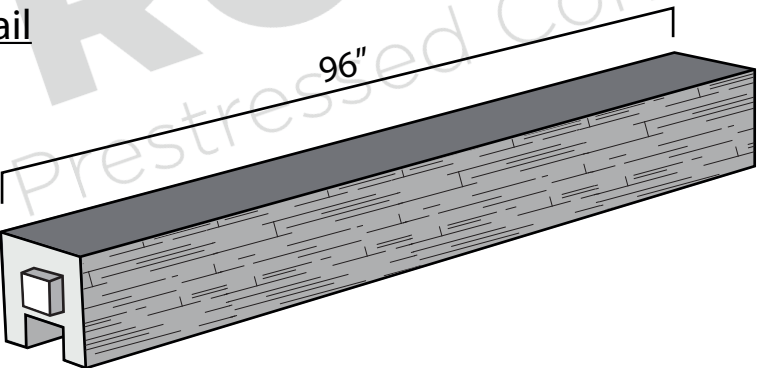

Concrete panel for fence

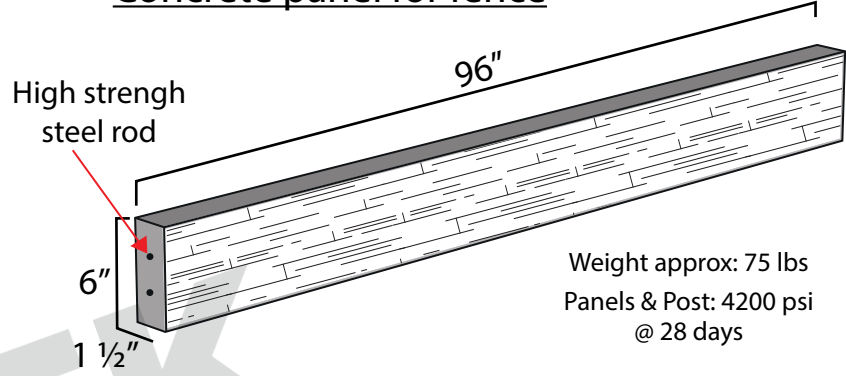

Weight approx: 75 lbs
Panels & Post: 4200 psi @ 28 days

Fence Post

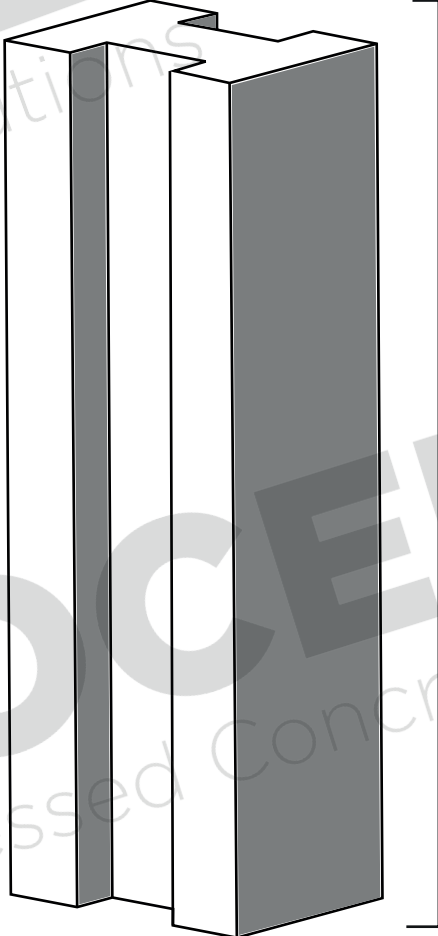
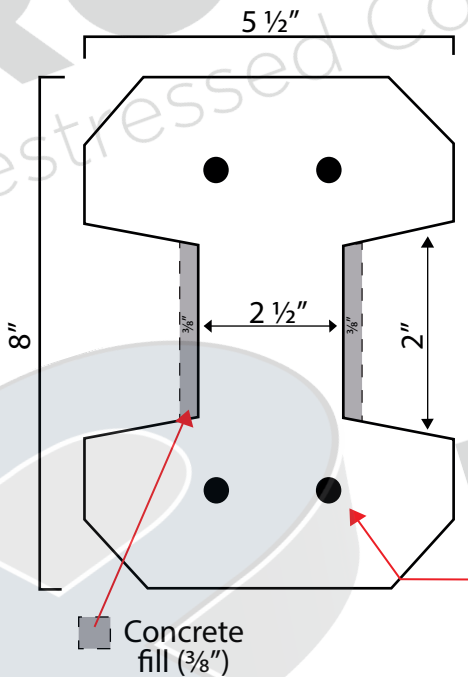

14 ft
Weight: 490 lbs
Panels & Post: 4200 psi @ 28 days

<https://www.proceltek.com>

info@proceltek.com

7. Add concrete around the post and compact it using a thick wood. Continue to filling the concrete to just under ground level and in the slot just above your mark.

Note: It is recommended that the cast concrete used to strain the base of the posts has a compressive strength of at least 2000 lb/in² (150kg/cm²), so the mortar is liquid enough to avoid air bubbles in the cast; adding rocks to the cast may also avoid them.

8. To facilitate installation, once posts are standing and leveled, place 2 metal/wood separating rules or scantlings inside the post "H" slots. (Figure C) The distance between the Post H slots should be 8 ft, 3/4"

9. Once posts are installed and concrete cast has hardened and dried (24 hours), you will begin placing the panels.

Note: You can pour concrete between panels and slots in Post "H" to avoid gaps between them.

10. Start by placing the first 6 panels of the whole fence, then continue placing them by section, and finish with the top rail.

11. It is important to use a level to make sure the bottom panel is totally straight

12. Repeat and continue, you can optimize the installation in any way you see fit.

13. Place the final concrete post, pour concrete, and level it. After that, measure the length of the slots between the posts, subtract 3/4" and cut the concrete panels with a concrete saw or concrete grind to that length.

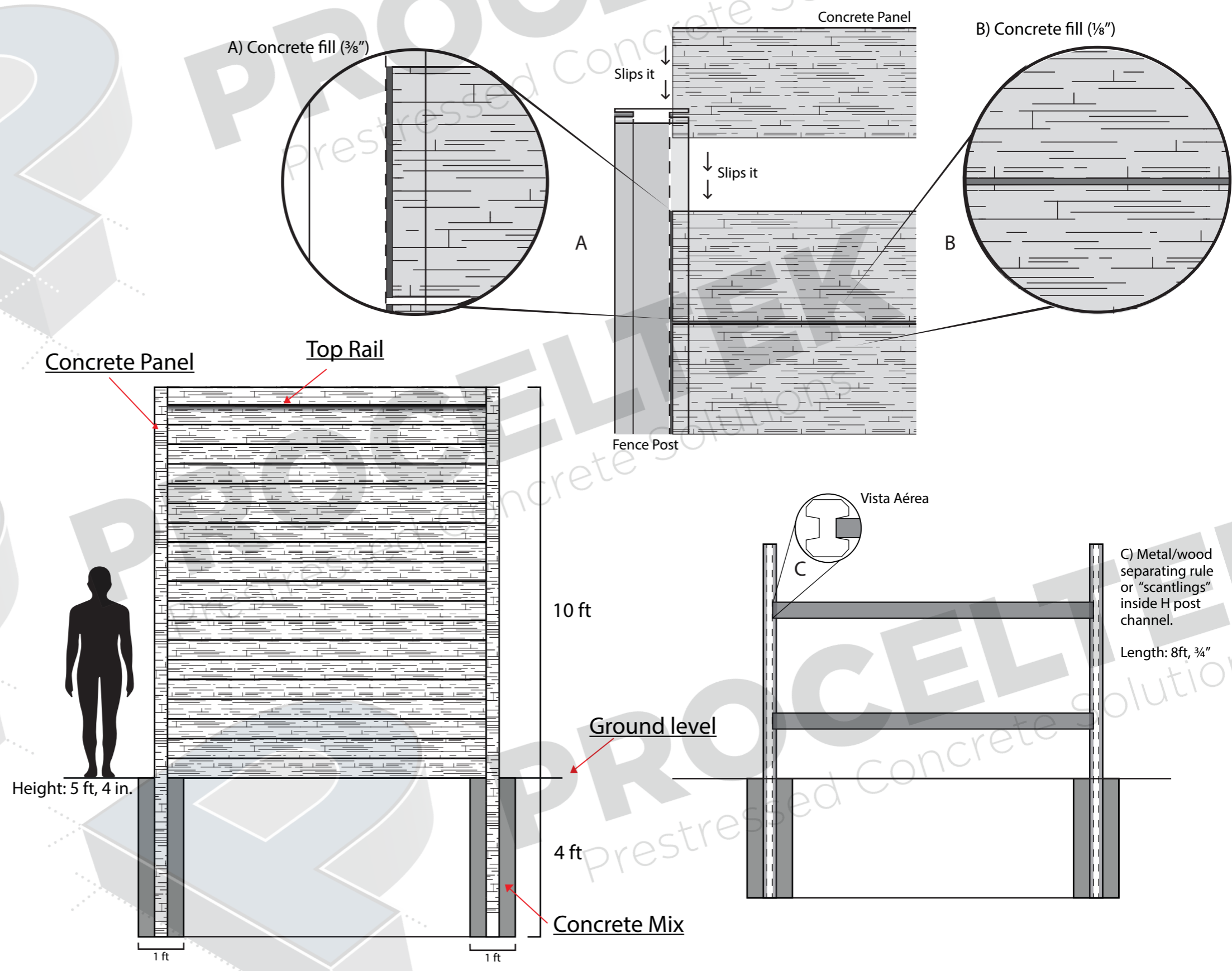

The contractor/owner is responsible for hiring a geotechnical engineer to determine if local soil conditions meet at least 92% soil compaction of at least 4 feet wide either way of the fence posts.